

Standard AC Motors

Torque Motors

Torque Motors

Introduction

Induction Motors

Reversible Motors

Electromagnetic Brake Motors

V Series

Clutch & Brake Motors

Synchronous Motors

Low-Speed Synchronous Motors

Waterright Dust-Resistant Motors

Torque Motors

Right-Angle Gearheads

Linear Heads

Brake Pack

Accessories

Installation

Torque Motors

● Additional Information ●
 Technical reference → Page G-1
 Safety standards → Page H-2

Torque motors are designed to provide high starting torque and sloping characteristics (torque is highest at zero speed and decreases steadily with increasing speed), and operate over a wide speed range. They also provide stable operation, especially in the low speed range or under a locked rotor condition.



● For detailed product safety standard information including standards, file number and certification body, please visit www.orientalmotor.com.



Features

● The Speed Can Vary Widely, Depending on the Sloping Characteristics

Torque motors have a high starting torque and sloping characteristics, allowing easy speed control simply by changing the voltage supplied to the motor. (The motor torque varies in proportion to the square of the voltage.)

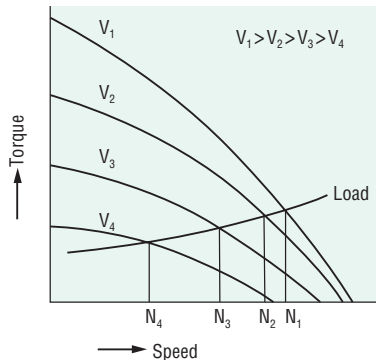

◇ Voltage Control of Torque Motors

The method most commonly used to control voltage is by phase control using a triac. As shown in Fig. 1, by changing the phase angle “alpha” at which the triac switches, the input voltage is controlled as represented by the shaded areas of the graph.

● When adjusting the speed or the torque, an external voltage adjuster is necessary.

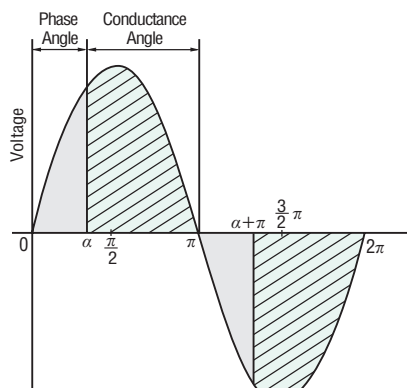
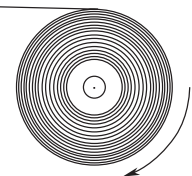

Fig. 1 Phase Control

● Suitable for Winding Applications

In an application where an object is released continuously at a constant speed and wound up with constant tension, the torque must be doubled and the speed must be halved if the diameter of the winding spool is doubled.

Constant Tension Wind Up



● Locked Rotor Operation is Available

Unlike induction motors or reversible motors, torque motors are designed to provide a stable torque even under locked rotor conditions or at very low speed (nearly locked rotor condition). They are suitable for pushing applications that require static torque, or for loads that are under locked rotor conditions at the end of processes.

Motors of 115 VAC input can operate continuously at 60 VAC. When used at voltages above 60 VAC, these motors have shorter time ratings. They have a 5 minutes rating at 115 VAC.

Note

● When using a motor in a locked rotor operation, the output torque becomes very large. The output torque of the gearhead must be lower than the maximum permissible torque. Also, ensure that the load does not hit an object and stop, since this can cause damage to the gearhead due to the shock.

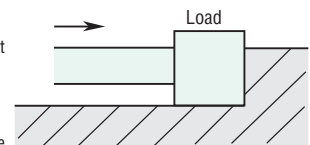

● Use as a Brake

By using the motor in the braking region of the speed – torque characteristics, it can serve as a brake. Constant tension control can be achieved by applying a DC voltage.

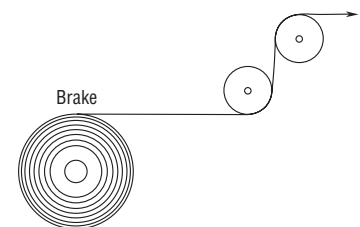

How to Use in a Brake Application

A torque motor has the following two characteristics that allow it to be used as a brake:

Reverse-phase brake: Brake characteristics obtained when AC voltage is applied to the motor and the motor is rotated in the direction opposite to the rotational magnetic field

Eddy-current brake: Brake characteristics obtained when DC voltage is applied to the motor

Unlike a brake pack or an electromagnetic brake that stop the motor, these reverse-phase brake and eddy-current brake characteristics are suited for winding mechanisms and other applications where tension (back-tension) control is required.

Application as a Reverse-Phase Brake

When a torque motor is used as a reverse-phase brake, connect the motor according to the connection diagram and apply AC voltage.

(→ Page C-225)

The motor operates at a speed balanced with the load according to the speed – torque characteristics (→ Page C-221), when the motor is not receiving any force that turns it in the direction opposite to the rotational magnetic field.

To use a torque motor as a brake, force the motor to rotate in the direction opposite to the rotational magnetic field at a torque greater than the starting torque of the motor. Then, the torque motor rotates in the direction opposite to the rotational magnetic field while generating a certain brake force.

Fig. 2 shows an example of speed – brake torque characteristics.

When a reverse-phase brake is used, a large brake force can be obtained at the speed of 0 r/min. The reverse-phase brake is suitable for applications where tension force is required even when the motor is at standstill.

Application as an Eddy-Current Brake

When a torque motor is used as an eddy-current brake, connect the red and white leadwires of the torque motor in series, as shown in Fig. 3, and apply DC voltage. At this time, insulate the black leadwire so that it will not contact any other part of the circuit.

Fig. 4 shows an example of speed – brake torque characteristics. The brake torque varies depending on the applied voltage and speed. When the speed is 0 r/min, the brake torque becomes 0 N·m (0 oz-in). The brake torque increases as the speed increases and stabilizes once the speed reaches a certain high level. A similar brake force can also be achieved whether the motor is rotating in the forward or reverse direction. An eddy-current brake is suitable for applications where tension force is required at high-speed operations or at bi-directional operations.

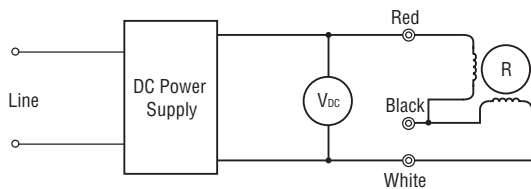

Note

- The black leadwire should be insulated.

Fig. 3

Connection Diagram for Eddy-Current Brake

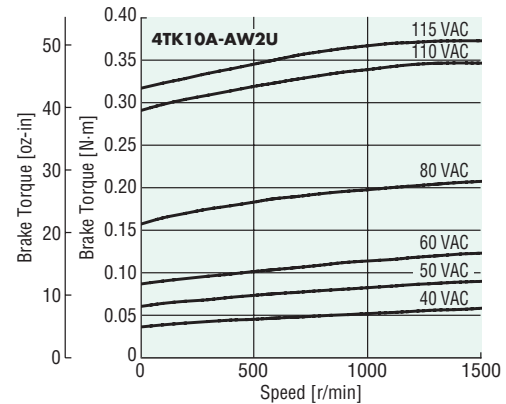

Fig. 2

Example of Speed – Brake Torque Characteristics with Reverse-Phase Brake (Reference values)

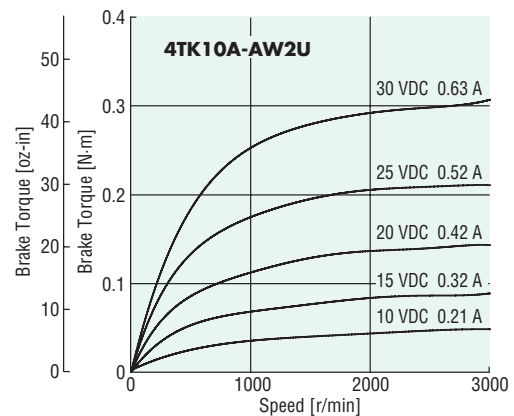

Fig. 4

Example of Speed – Brake Torque Characteristics with Eddy-Current Brake (Reference values)

Notes

- When a torque motor is used as a brake, continuous operating time varies depending on the specific conditions.
- If a torque motor is combined with a gearhead, keep the speed to 2400 r/min or below.

● Conforms to Major Safety Standards and Global Power Supply Voltages

Torque Motors are recognized by UL and CSA, and certified under the China Compulsory Certification System (CCC System). CE Marking is used in accordance with the Low Voltage Directive. Also, our wide range of products includes those that meet the power supply voltages of major countries in Asia, North America and Europe.

● The Motor Bearing Life is Twice as Long as a Conventional Type

A motor's life is determined by its bearing. We adopted high-performance bearing grease to lubricate this important component. As a result, the bearings of motors last twice as long as our conventional bearings.

● Protective Earth Terminal on the Motor

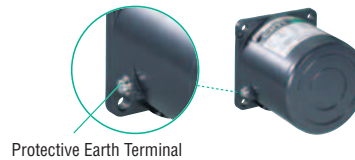

■ Features and Types of Gearheads

● Long Life, Low Noise GN-S Gearhead is Available

Adopting innovative technologies and structure, the "long life, low noise GN-S gearhead" achieves a long rated life of 10000 hours, twice as long as the level of a conventional gearhead. Also, the gearhead is designed for low noise.

● Details of long life, low-noise GN-S gearhead → Page C-21



● Types of Gearheads

Gearhead		Applicable Motor		Rated Life (hours)	Low Noise
Type of Gearhead	Type of Pinion	Output Power	Type of Pinion		
Parallel Shaft	Long Life, Low Noise GN-S Gearhead	GN Type Pinion Shaft	3 W~20 W (1/250 HP~1/38 HP)	10000	●
	GN-K Gearhead	GN Type Pinion Shaft	3 W~20 W (1/250 HP~1/38 HP)	5000	

Note

● The right-angle gearheads cannot be combined.

Power Controller TMP-1

The Power Controller **TMP-1** makes torque adjustment easy.

A new power controller developed for Oriental Motor's torque motors that allows for easy adjustment of torque. A perfect choice for winding applications, push-motion mechanisms and other situations where torque must be adjusted.

For details on this product please refer to our website, contact technical support or your nearest Oriental Motor sales office.
www.orientalmotor.com



Power Controller for Torque Motors (**TMP-1**)



Torque Motor and Gearhead

(Torque Motor, gearhead and power controller sold separately)

■ Product Line (RoHS)

Model	Power Supply Voltage
TMP-1	Single-Phase 100-115 VAC
	Single-Phase 200-230 VAC

■ Features

● Motor Torque can be Adjusted with Ease

You can set/adjust motor torque using the internal torque potentiometer of the power controller.

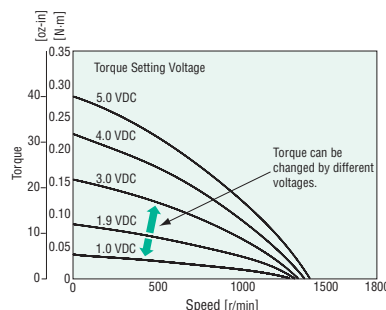
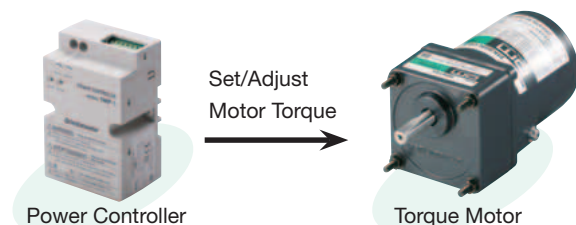

Speed – Torque Characteristics (Example)

System Configuration

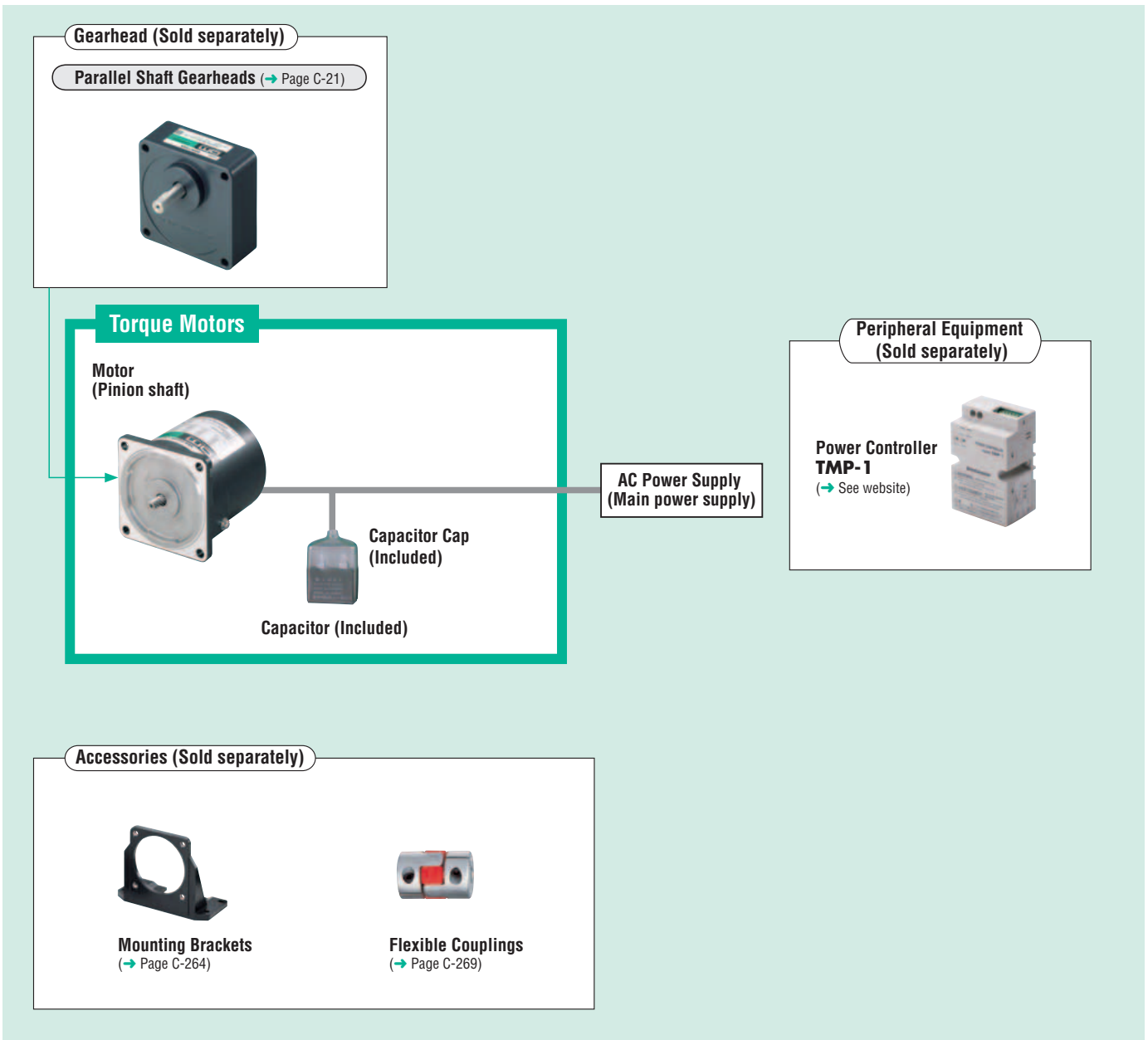

● Example of System Configuration

Torque Motor (Pinion shaft)	Sold Separately		+	Sold Separately	
	Long Life, Low Noise Gearhead			Mounting Bracket	Flexible Coupling
4TK10GN-AW2U	4GN25SA			SOL4U10	MCL30F06F06

● Gearheads cannot be combined with round shaft type motors.

● The system configuration shown above is an example. Other combinations are available.

Introduction

Induction
Motors

Reversible
Motors

Electromagnetic
Brake Motors

V Series

Clutch &
Brake Motors

Synchronous
Motors

Low-Speed
Synchronous
Motors

Water-tight
Dust-Resistant
Motors

Torque
Motors

Right-Angle
Gearheads

Linear Heads

Brake Pack

Accessories

Installation

Product Number Code

Motor

5 T K 20 GN - AW 2 U

① ② ③ ④ ⑤ ⑥ ⑦ ⑧

Gearhead

5 GN 50 SA

① ② ③ ④

Product Line

Motor (RoHS)

Output Power	Model	
	Pinion Shaft Type	Round Shaft Type
3 W (1/250 HP)	2TK3GN-AW2U	2TK3A-AW2U
	2TK3GN-CW2E	2TK3A-CW2E
6 W (1/125 HP)	3TK6GN-AW2U	3TK6A-AW2U
	3TK6GN-CW2E	3TK6A-CW2E
10 W (1/75 HP)	4TK10GN-AW2U	4TK10A-AW2U
	4TK10GN-CW2E	4TK10A-CW2E
20 W (1/38 HP)	5TK20GN-AW2U	5TK20A-AW2U
	5TK20GN-CW2E	5TK20A-CW2E

The following items are included in each product.
Motor, Capacitor, Capacitor Cap, Operating Manual

①	Motor Frame Size	2: 60 mm (2.36 in.) 3: 70 mm (2.76 in.) 4: 80 mm (3.15 in.) 5: 90 mm (3.54 in.)
②	Motor Type	T: Torque Motor
③	Series	K: K Series
④	Output Power (W)	(Example) 20: 20 W (1/38 HP)
⑤	Motor Shaft Type, Type of Pinion	A: Round Shaft GN: GN Type Pinion Shaft
⑥	Power Supply Voltage	AW: Single-Phase 110/115 VAC CW: Single-Phase 220/230 VAC
⑦	2: RoHS-Compliant	
⑧	Included Capacitor	U: For Single-Phase 110/115 VAC E: For Single-Phase 220/230 VAC

The **U** and **E** at the end of the model name indicate that the unit includes a capacitor. These letters are not listed on the motor nameplate.

When the motor is approved under various safety standards, the model name on the nameplate is the approved model name.

(Example) Model: **5TK20GN-AW2U**

→ Motor nameplate and product approved under various safety standards: **5TK20GN-AW2**

①	Gearhead Frame Size	2: 60 mm (2.36 in.) 3: 70 mm (2.76 in.) 4: 80 mm (3.15 in.) 5: 90 mm (3.54 in.)
②	Type of Pinion	GN: GN Type Pinion
③	Gear Ratio	(Example) 50: Gear Ratio of 50:1 10X denotes the decimal gearhead of gear ratio 10:1
④	SA: Long Life, Low Noise GN-S Gearhead	

Note

The right-angle gearhead cannot be combined.

Parallel Shaft Gearhead (Sold separately)

Long Life, Low Noise GN-S Gearhead (RoHS)

Applicable Motor Output Power (Pinion shaft type)	Gearhead Model	Gear Ratio
3 W (1/250 HP)	2GN□SA	3, 3.6, 5, 6, 7.5, 9, 12.5, 15, 18, 25, 30, 36, 50, 60, 75, 90, 100, 120, 150, 180
	2GN10XS (Decimal gearhead)	
6 W (1/125 HP)	3GN□SA	3, 3.6, 5, 6, 7.5, 9, 12.5, 15, 18, 25, 30, 36, 50, 60, 75, 90, 100, 120, 150, 180
	3GN10XS (Decimal gearhead)	
10 W (1/75 HP)	4GN□SA	3, 3.6, 5, 6, 7.5, 9, 12.5, 15, 18, 25, 30, 36, 50, 60, 75, 90, 100, 120, 150, 180
	4GN10XS (Decimal gearhead)	
20 W (1/38 HP)	5GN□SA	3, 3.6, 5, 6, 7.5, 9, 12.5, 15, 18, 25, 30, 36, 50, 60, 75, 90, 100, 120, 150, 180
	5GN10XS (Decimal gearhead)	

The following items are included in each product.
Gearhead, Mounting Screws, Operating Manual

The following gearheads are also available. For details, please refer to website (www.orientalmotor.com) or contact the nearest Oriental Motor sales office.

Gearhead Type	Gearhead Model	Gear Ratio
Parallel Shaft (RoHS) GN-K Gearhead	2GN□KA	3~180
	2GN10XK (Decimal gearhead)	
	3GN□KA	3~180
	3GN10XK (Decimal gearhead)	
	4GN□KA	3~180
	4GN10XK (Decimal gearhead)	
	5GN□KA	3~180
	5GN10XK (Decimal gearhead)	

Enter the gear ratio in the box (□) within the model name.



Specifications RoHS

Model		Rating at Locked Rotor	Voltage	Frequency	Starting Torque		Max. Output Power		Speed at Max. Output Power r/min	Torque at Max. Output Power		Current at Max. Output Power A	Input Power at Max. Output Power W	Capacitor μF
Pinion Shaft Type	Round Shaft Type				VAC	Hz	mN·m	oz-in		W	HP			
TP 2TK3GN-AW2U	2TK3A-AW2U	5 minutes	110	60	70	9.9	3.5	1/210	900	38	5.3	0.42	45	6.0
			115									0.45	50	
TP 2TK3GN-CW2E	2TK3A-CW2E	5 minutes	220	50	70	9.9	3	1/250	750	39	5.5	0.220	45	1.5
			230									0.240	50	
TP 3TK6GN-AW2U	3TK6A-AW2U	5 minutes	220	60	18	2.5	0.8	1/930	750	10	1.42	0.095	10	9.0
			230									0.130	14	
TP 3TK6GN-CW2E	3TK6A-CW2E	5 minutes	110	60	150	21	8	1/93	900	87	12.3	0.60	65	2.5
			115									0.65	70	
TP 4TK10GN-AW2U	4TK10A-AW2U	5 minutes	220	50	140	19.8	6	1/125	750	78	11.0	0.390	70	11
			230									0.440	80	
TP 4TK10GN-CW2E	4TK10A-CW2E	5 minutes	220	60	150	21	8	1/93	900	87	12.3	0.320	70	3.0
			230									0.350	75	
TP 5TK20GN-AW2U	5TK20A-AW2U	5 minutes	110	60	350	49	23	1/32	900	250	35	1.00	110	14
			115									1.02	115	
TP 5TK20GN-CW2E	5TK20A-CW2E	5 minutes	60	60	100	14.2	5.5	1/140	900	60	8.5	0.58	34	4.0
			220									0.63	120	
TP 5TK20GN-AW2U	5TK20A-AW2U	5 minutes	230	50	350	49	20	1/38	750	260	36	0.68	130	14
			220									0.53	115	
TP 5TK20GN-CW2E	5TK20A-CW2E	5 minutes	230	60	350	49	20	1/38	900	220	31	0.54	120	4.0
			115									0.26	29	
TP 5TK20GN-AW2U	5TK20A-AW2U	5 minutes	60	60	100	14.2	5.5	1/140	900	60	8.5	0.30	34	4.0
			220									0.30	34	

TP: Contains a built-in thermal protector (automatic return type). If a motor overheats for any reason, the thermal protector is activated and the motor is stopped. When the motor temperature drops, the thermal protector closes and the motor restarts. Be sure to turn the motor power off before inspecting.

General Specifications

Item	Specifications
Insulation Resistance	100 MΩ or more when 500 VDC megger is applied between the windings and the case after rated operation under normal ambient temperature and humidity.
Dielectric Strength	Sufficient to withstand 1.5 kVAC at 50 Hz or 60 Hz applied between the windings and the case for 1 minute after rated operation under normal ambient temperature and humidity.
Temperature Rise	Temperature rise of windings is 80°C (144°F) or less measured by the resistance change method after rated operation under normal ambient temperature and humidity with connecting a gearhead or equivalent heat radiation plate*.
Thermal Class	130 (B)
Overheat Protection	Built-in thermal protector (automatic return type) 3 W (1/250 HP) type Open: 130±5°C (266±9°F), Close: 90±15°C (194±27°F) Other type Open: 130±5°C (266±9°F), Close: 82±15°C (179.6±27°F)
Ambient Temperature	-10~+40°C (+14~+104°F) (non-freezing)
Ambient Humidity	85% or less (non-condensing)
Degree of Protection	IP20

* Heat radiation plate (Material: Aluminum)

Motor Type	Size: mm (in.)	Thickness: mm (in.)
3 W (1/250 HP) Type	115×115 (4.53×4.53)	5 (0.20)
6 W (1/125 HP) Type	125×125 (4.92×4.92)	
10 W (1/75 HP) Type	135×135 (5.31×5.31)	
20 W (1/38 HP) Type	165×165 (6.50×6.50)	

How to Read Speed – Torque Characteristics

The motor torque varies approximately in proportion to the square of the voltage. When the voltage supplied to the motor is changed, speed – torque characteristics curves with a sloping characteristics (torque is highest at zero speed and decreases steadily with increasing speed) shifts to that of the corresponding voltage. When the voltage is changed to 115 VAC, 80 VAC and 60 VAC while the load torque is T_0 , the motor rotates at the speeds N_1 , N_2 and N_3 respectively. Thus, the speed can be changed easily by varying the voltage.

When choosing a torque motor, first determine the required torque and speed. Then, determine whether the motor should be operated under continuous duty or limited duty and check the speed – torque characteristics. When used under locked rotor conditions, only the torque factor is considered.

The temperature rise of the motor may cause a problem during continuous operation. In this case, choose a motor with an output power large enough for continuous operation and adjust the voltage to control the torque and speed.

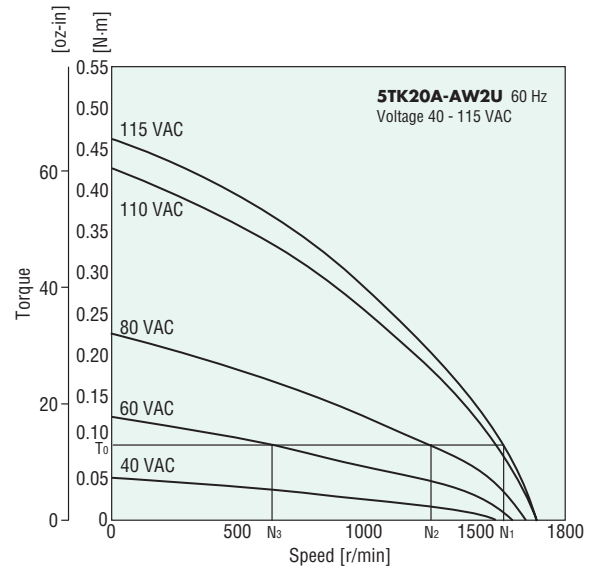

Output Torque of Gearmotor

Due to the sloping characteristics, torque motors can be operated over a wide speed range, from standstill to the maximum speed. The permissible torque when a gearhead and a decimal gearhead are connected can be calculated according to the following formula, using the speed and torque determined from the speed – torque characteristics.

$$\begin{aligned} \text{Speed of gearhead output shaft } N_g &= \text{Motor speed} \times 1/\text{gearhead gear ratio} \\ \text{Output torque of gearhead } T_g &= \text{Motor torque} \times \text{Gearhead gear ratio} \times \text{Gearhead efficiency} \end{aligned}$$

The output torque of gearhead must be lower than the maximum permissible torque.

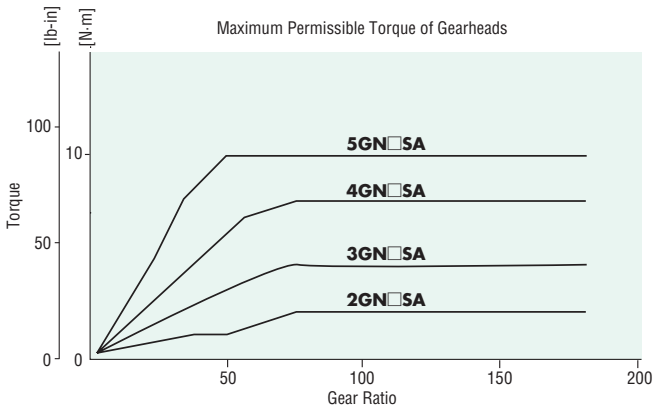

Gearhead Model	Gearhead Gear Ratio	Gearhead Efficiency
2GN□SA	3~18	81%
3GN□SA	25~36	73%
4GN□SA	50~180	66%

- Gearheads and decimal gearheads are sold separately.
- Enter the gear ratio in the box (□) within the model name.
- The direction of gearhead shaft rotation may differ from motor shaft rotation depending on the gear ratio of gearhead. Gear ratio and rotation direction of gearhead → Page C-15

Speed – Torque Characteristics (Reference values)

2TK3GN-AW2U, 2TK3A-AW2U

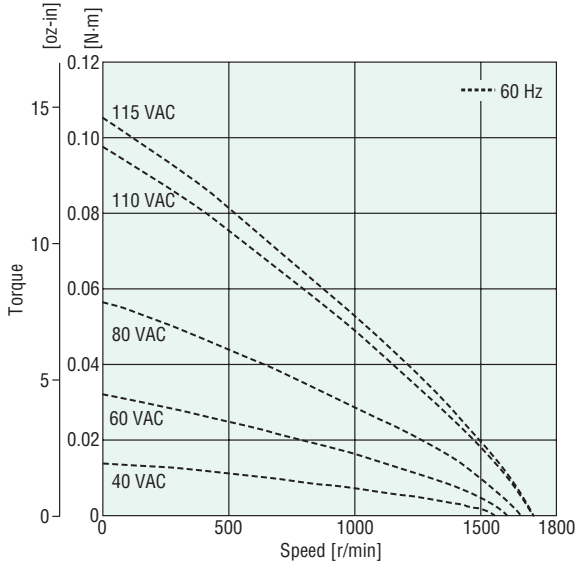

2TK3GN-CW2E, 2TK3A-CW2E

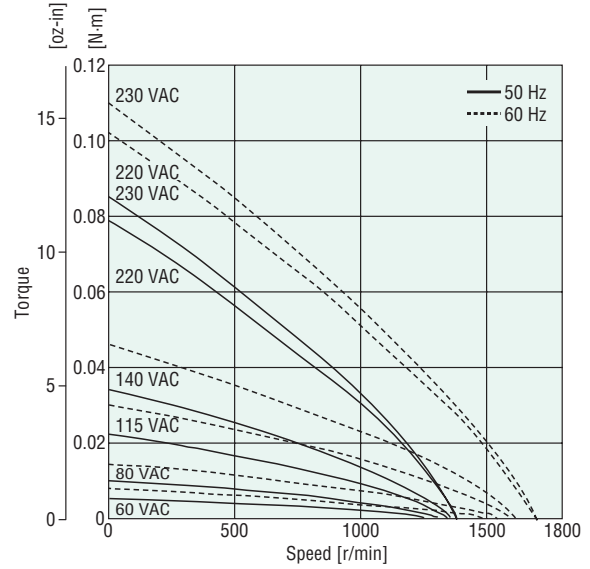

3TK6GN-AW2U, 3TK6A-AW2U

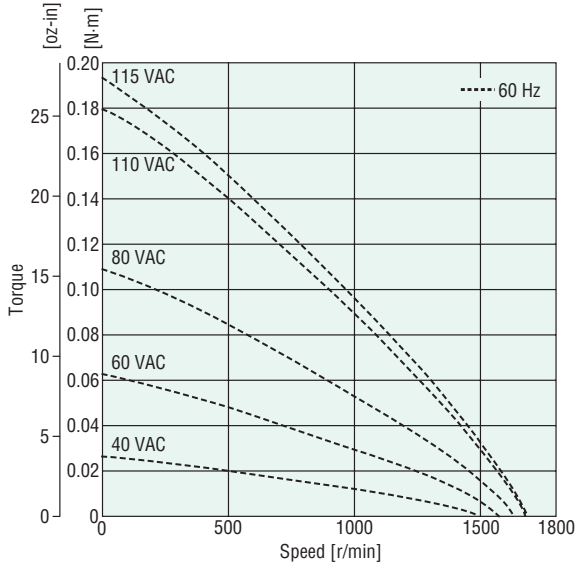

3TK6GN-CW2E, 3TK6A-CW2E

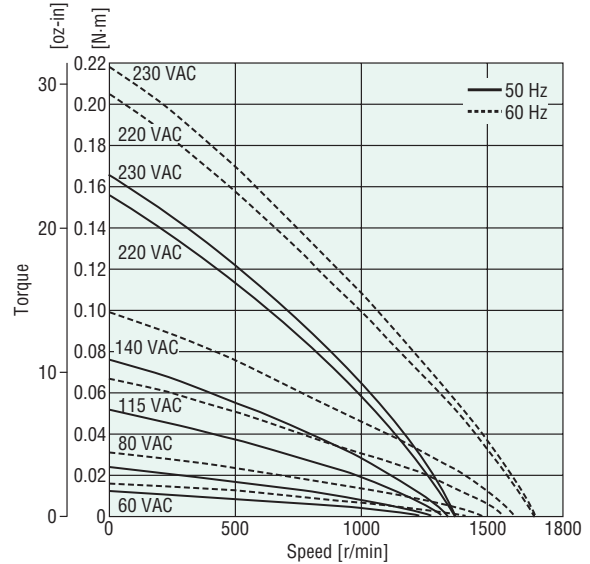

4TK10GN-AW2U, 4TK10A-AW2U

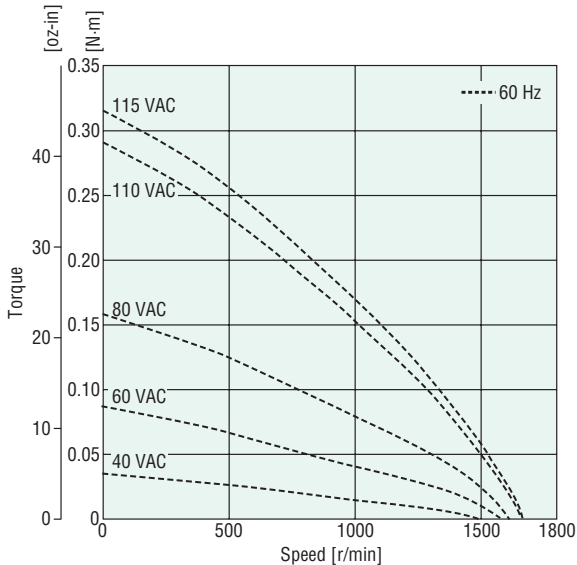

4TK10GN-CW2E, 4TK10A-CW2E

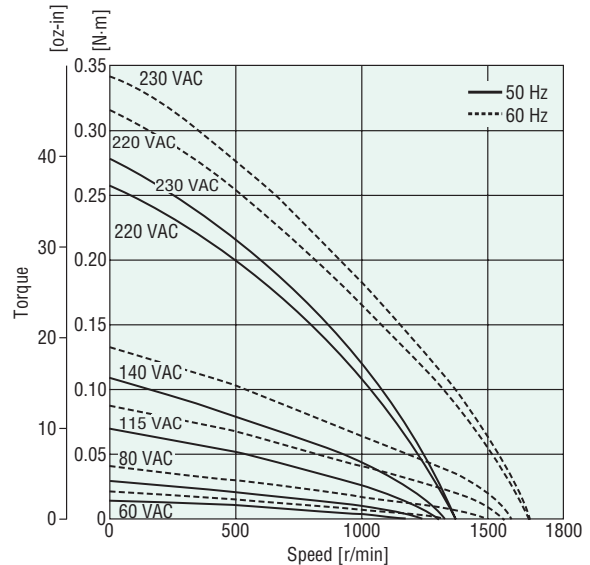

- Introduction
- Induction Motors
- Reversible Motors
- Electromagnetic Brake Motors
- V Series
- Clutch & Brake Motors
- Synchronous Motors
- Low-Speed Synchronous Motors
- Waterright Dust-Resistant Motors
- Torque Motors
- Right-Angle Gearheads
- Linear Heads
- Brake Pack
- Accessories
- Installation

5TK20GN-AW2U, 5TK20A-AW2U

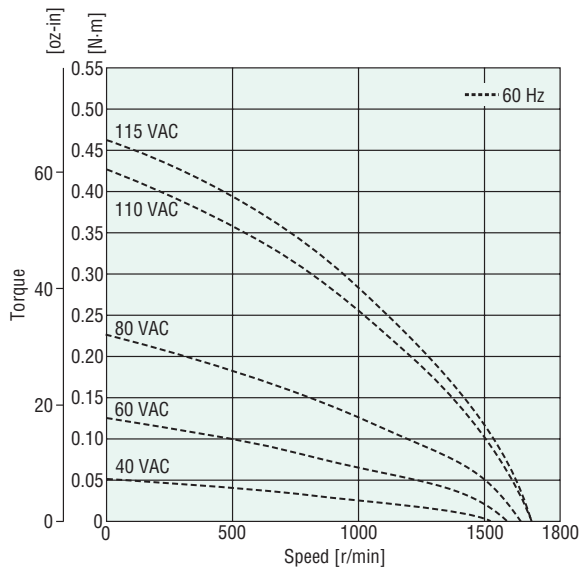

5TK20GN-CW2E, 5TK20A-CW2E

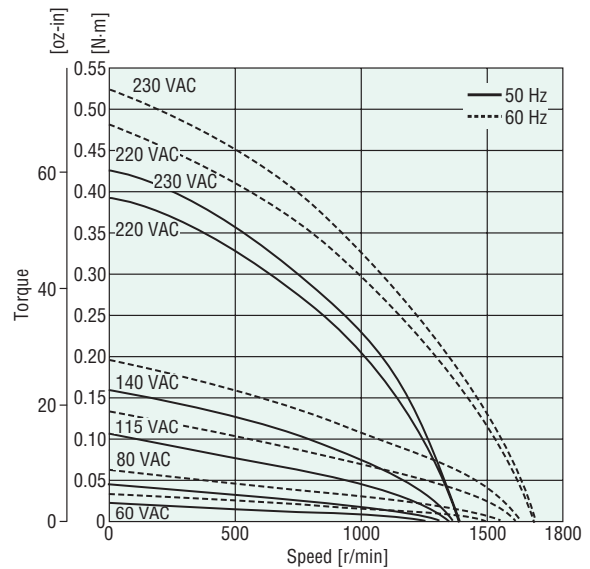

Dimensions Unit = mm (in.)

● Mounting screws are included with gearheads. Dimensions for mounting screws → Page C-280

● 3 W (1/250 HP)

◇ Motor/Gearhead

Mass: Motor 0.7 kg (1.54 lb.)
Gearhead 0.4 kg (0.88 lb.)

Motor Model	Gearhead Model	Gear Ratio	L	DXF
2TK3GN-AW2U 2TK3GN-CW2E	2GN□SA	3~18	30 (1.18)	A443AU
		25~180	40 (1.57)	A443BU

● Enter the gear ratio in the box (□) within the model name.

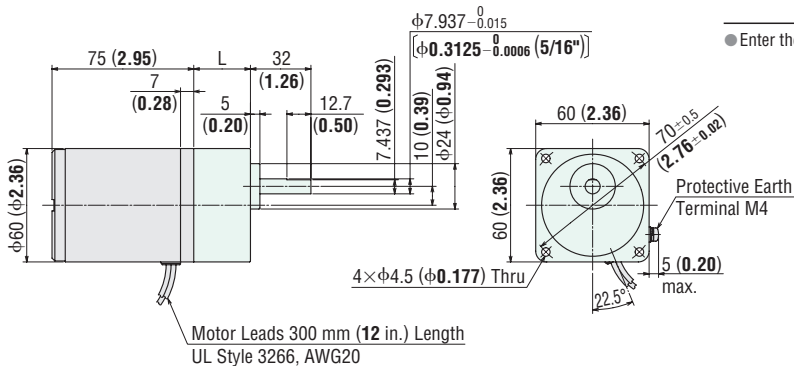

Detail Drawing of Protective Earth Terminal

◇ Shaft Section of Round Shaft Type

The motor's dimensions (excluding the shaft section) are the same as those of the pinion shaft types.

2TK3A-AW2U **2TK3A-CW2E**

Mass: 0.7 kg (1.54 lb.)

DXF A444

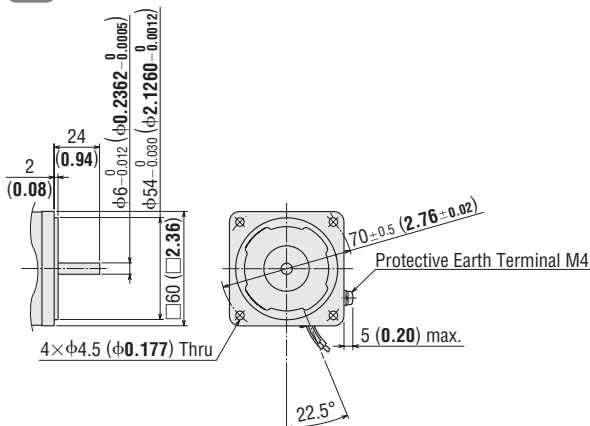

◇ Decimal Gearhead

Can be connected to **2TK3GN** type.

2GN10XS

Mass: 0.2 kg (0.44 lb.)

DXF A003

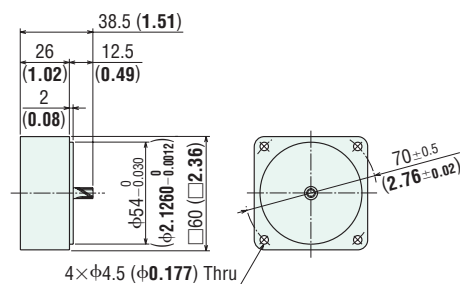

● 6 W (1/125 HP)

◇ Motor/Gearhead

Mass: Motor 1.1 kg (2.4 lb.)
Gearhead 0.55 kg (1.21 lb.)

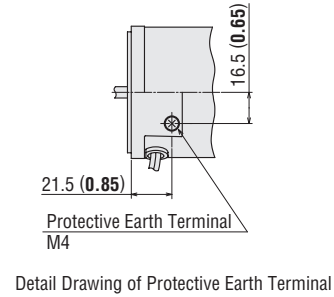
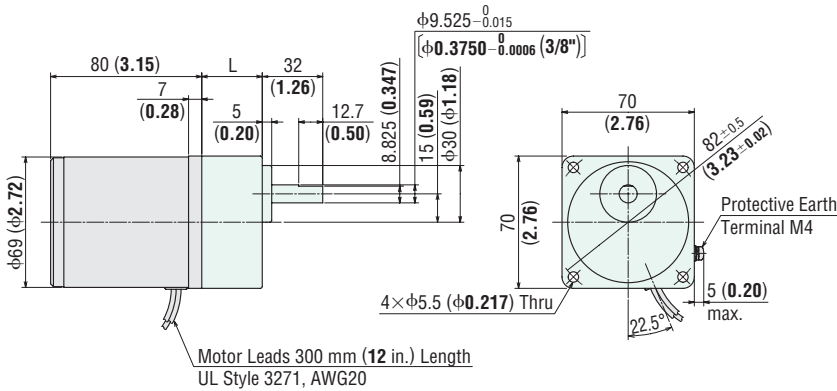

◇ Shaft Section of Round Shaft Type

The motor's dimensions (excluding the shaft section) are the same as those of the pinion shaft types.

3TK6A-AW2U 3TK6A-CW2E

Mass: 1.1 kg (2.4 lb.)

DXF A448

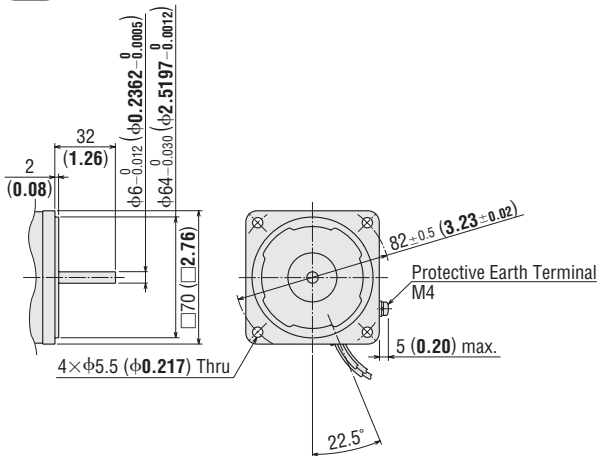

Motor Model	Gearhead Model	Gear Ratio	L	DXF
3TK6GN-AW2U 3TK6GN-CW2E	3GN□SA	3~18	32 (1.26)	A447AU
		25~180	42 (1.65)	A447BU

◇ Decimal Gearhead

Can be connected to 3TK6GN type.

3GN10XS

Mass: 0.3 kg (0.66 lb.)

DXF A009

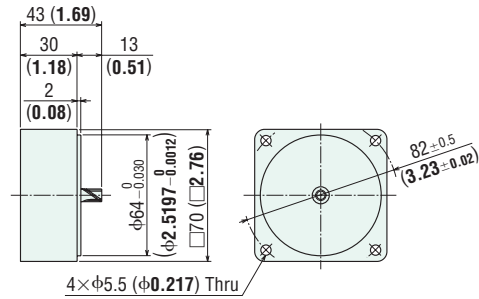

● 10 W (1/75 HP)

◇ Motor/Gearhead

Mass: Motor 1.5 kg (3.3 lb.)
Gearhead 0.65 kg (1.43 lb.)

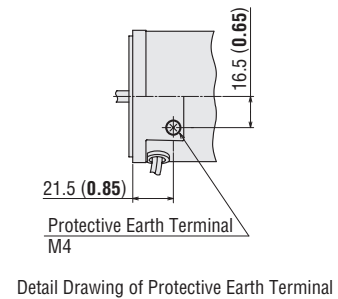
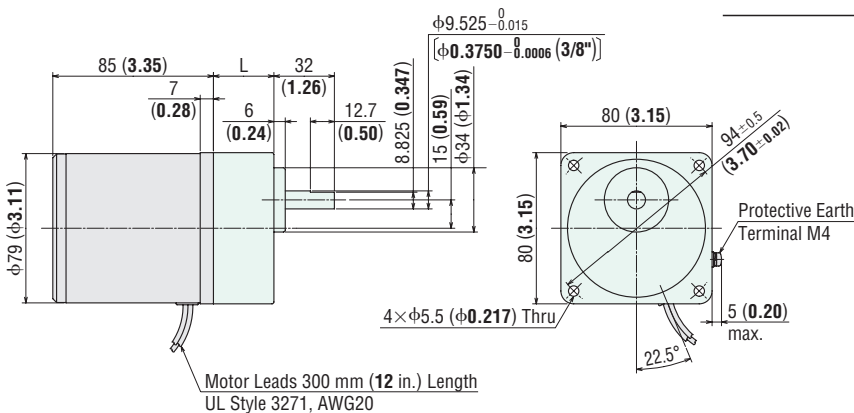

Motor Model	Gearhead Model	Gear Ratio	L	DXF
4TK10GN-AW2U 4TK10GN-CW2E	4GN□SA	3~18	32 (1.26)	A449AU
		25~180	42.5 (1.67)	A449BU

● Enter the gear ratio in the box (□) within the model name.

◇ Shaft Section of Round Shaft Type

The motor's dimensions (excluding the shaft section) are the same as those of the pinion shaft types.

4TK10A-AW2U

4TK10A-CW2E

Mass: 1.5 kg (3.3 lb.)

DXF A450

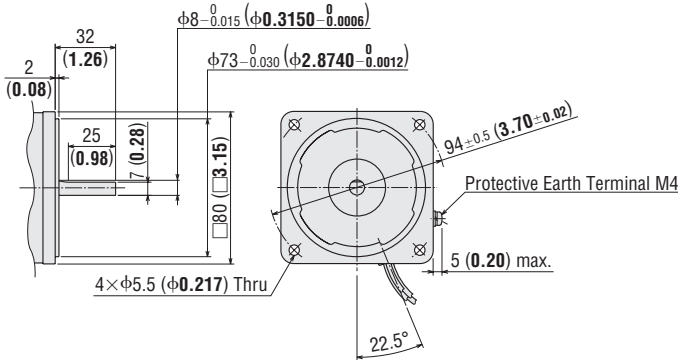

◇ Decimal Gearhead

Can be connected to **4TK10GN** type.

4GN10XS

Mass: 0.4 kg (0.88 lb.)

DXF A013

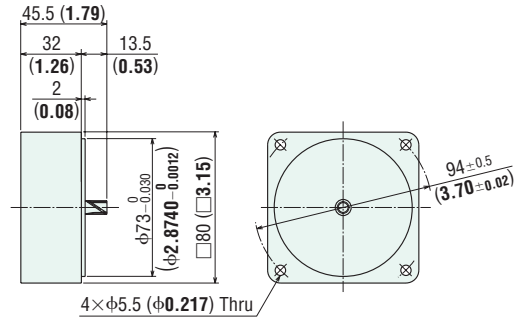

● 20 W (1/38 HP)

◇ Motor/Gearhead

Mass: Motor 2.5 kg (5.5 lb.)

Gearhead 1.5 kg (3.3 lb.)

Motor Model	Gearhead Model	Gear Ratio	L	DXF
5TK20GN-AW2U 5TK20GN-CW2E	5GN□SA	3~18	42 (1.65)	A452AU
		25~180	60 (2.36)	A452BU

● Enter the gear ratio in the box (□) within the model name.

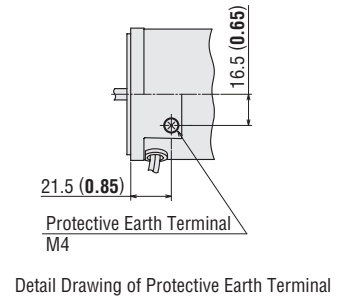
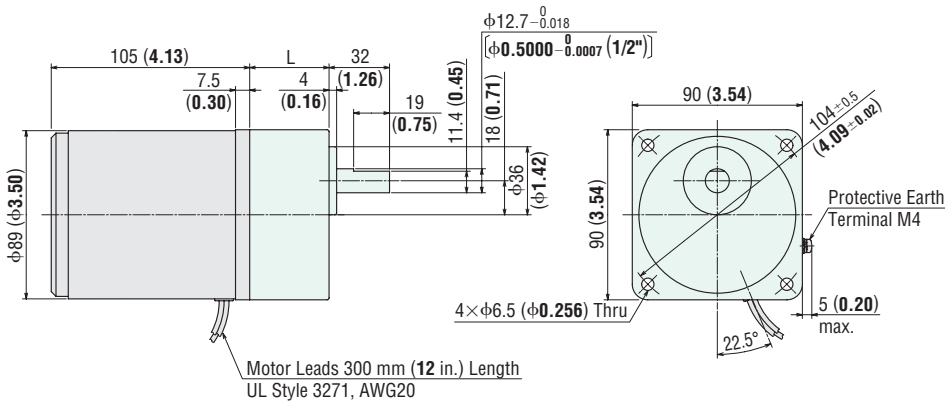

◇ Shaft Section of Round Shaft Type

The motor's dimensions (excluding the shaft section) are the same as those of the pinion shaft types.

5TK20A-AW2U

5TK20A-CW2E

Mass: 2.5 kg (5.5 lb.)

DXF A453

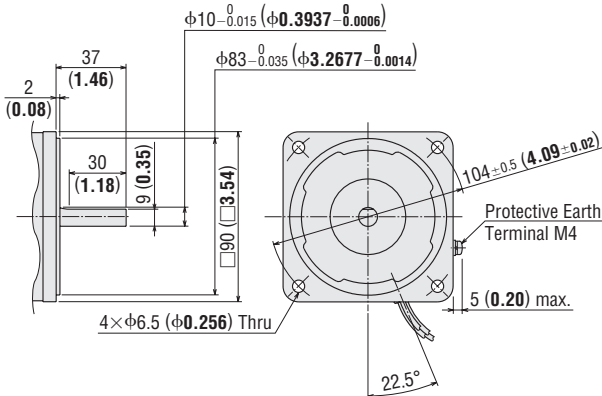

◇ Decimal Gearhead

Can be connected to **5TK20GN** type.

5GN10XS

Mass: 0.6 kg (1.32 lb.)

DXF A022

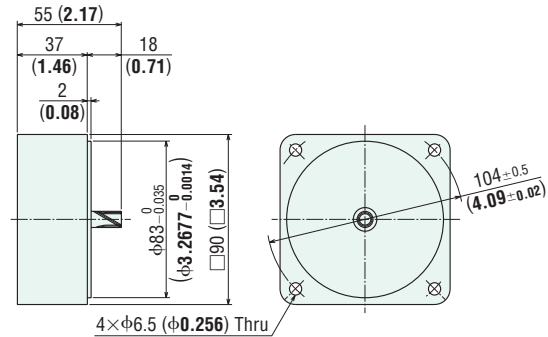

◇ Capacitor (Included with the motors)

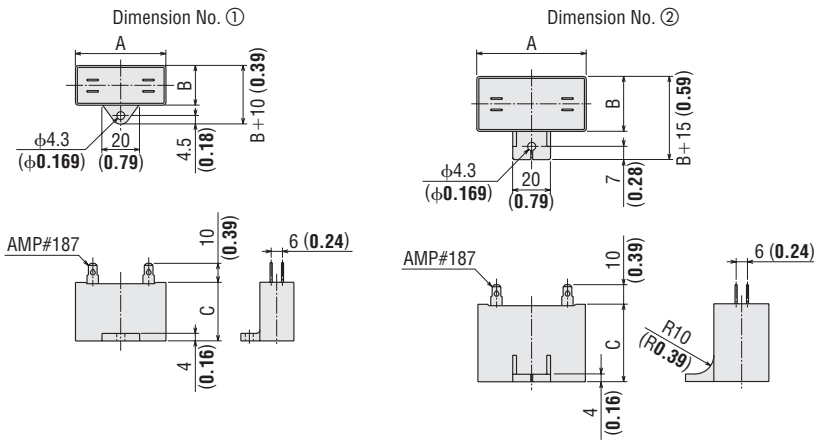

◇ Capacitor Dimensions Unit = mm (in.)

Model		Capacitor Model	A	B	C	Mass g (oz.)	Dimension No.	Capacitor Cap
Pinion Shaft Type	Round Shaft Type							
2TK3GN-AW2U	2TK3A-AW2U	CH60CFAUL2	38 (1.50)	21 (0.83)	31 (1.22)	35 (1.24)	①	Included
2TK3GN-CW2E	2TK3A-CW2E	CH15BFAUL	38 (1.50)	21 (0.83)	31 (1.22)	37 (1.31)	①	
3TK6GN-AW2U	3TK6A-AW2U	CH90CFAUL2	48 (1.89)	22.5 (0.89)	31.5 (1.24)	45 (1.59)	①	
3TK6GN-CW2E	3TK6A-CW2E	CH25BFAUL	48 (1.89)	21 (0.83)	31 (1.22)	42 (1.48)	①	
4TK10GN-AW2U	4TK10A-AW2U	CH110CFAUL2	58 (2.28)	21 (0.83)	31 (1.22)	49 (1.73)	①	
4TK10GN-CW2E	4TK10A-CW2E	CH30BFAUL	58 (2.28)	21 (0.83)	31 (1.22)	50 (1.77)	①	
5TK20GN-AW2U	5TK20A-AW2U	CH140CFAUL2	58 (2.28)	22 (0.87)	35 (1.38)	61 (2.2)	①	
5TK20GN-CW2E	5TK20A-CW2E	CH40BFAUL	58 (2.28)	23.5 (0.93)	37 (1.46)	73 (2.6)	②	

Connection Diagrams

- The direction of motor rotation is as viewed from the shaft end of the motor. CW represents the clockwise direction, while CCW represents the counterclockwise direction.
- Connection diagrams are also valid for the equivalent round shaft type.

2TK3GN-AW2U, 2TK3GN-CW2E, 3TK6GN-AW2U, 3TK6GN-CW2E
4TK10GN-AW2U, 4TK10GN-CW2E, 5TK20GN-AW2U, 5TK20GN-CW2E

Clockwise

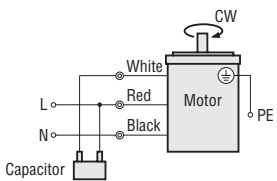

Counterclockwise

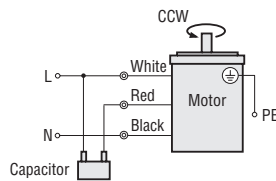

PE: Protective Earth

- How to connect a capacitor → Page C-282

